

**PRESSE / PRESSES / PRESEN /  
PRESSES / PRENSAS**

Presse idrauliche manuali  
con pompa a due velocità  
automatiche e valvola di  
taratura.

*Hydraulic presses with hand  
pump, two automatic speeds and  
calibration valve.*

Hydraulische Werkstattpressen  
mit Handpumpe mit zwei  
automatischen Geschwindigkeiten  
und Eichventil.

*Presses hydrauliques manuelles  
avec pompe à double vitesse  
automatique et soupape de  
tarage.*

Presas hidráulicas manuales  
con bomba de dos velocidades  
automáticas y válvula de  
calibrado.



	DIMENSIONI / DIMENSIONS / ABMESSUNGEN / DIMENSIONS / DIMENSIONES (mm)													
	A	B	C	D	E	F	G	H	L	M	N	O	P	R
PX15	1970	890	500	530	124	712	1328	987	Ø 45	170	162	1700	1149	341
PX30	2018	1028	650	650	180	788	1296	987	Ø 55	210	205	1770	1191	309

					PX15	PX30	
Potenza	Capacity	Druckleistung	Force	Potencia	ton	15	30
Pressione max.	Max. pressure	Max. Druck	Pression maxi	Presión máx.	bar	390	425
Avanzamento stelo per pompata lento	Shaft feed by one pump stroke, slow	Schaftvorschub bei jeder Pumptätigkeit, langsam	Avance du piston chaque coup de pompe, lente	Avance vástago por recorrido de bomba, lento	mm	0,80	0,43
Avanzamento stelo per pompata rapido	Shaft feed by one pump stroke, quick	Schaftvorschub bei jeder Pumptätigkeit, schnell	Avance du piston chaque coup de pompe, rapide	Avance vástago por recorrido de bomba, rápido	mm	4,8	2,7
Peso	Weight	Gewicht	Poids	Peso	kg	130	230

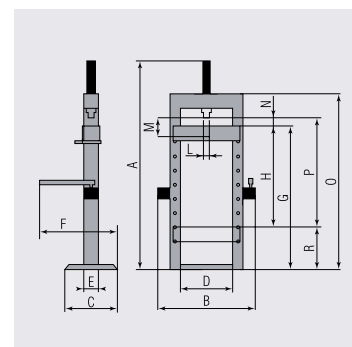

**VASCHE A CALDO / WASHING TANKS WITH HEATED WATER / HEISSWASSER TEILE WASCHMASCHINE /  
BACS DE LAVAGE A EAU CHAUDE / LAVADORAS DE PIEZAS DE AGUA CALIENTE**



**VE 1200M**  
• Ø = 1200 mm  
• 220 litres



**VE 1000M**  
• Ø = 1000 mm  
• 175 litres



**VE 800M**  
• Ø = 800 mm  
• 100 litres

**Motor Rotation**



CAVALLETTI MOTORE / ENGINE STANDS / MOTORBÖCKE /  
SUPPORT MOTEURS / SUPORTES PARA MOTORES



**R10**  
• 500 kg



**R12**  
• 800 kg



**R11**  
• 1.200 kg

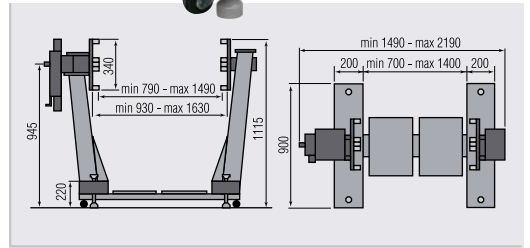
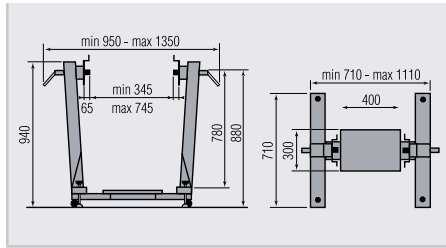
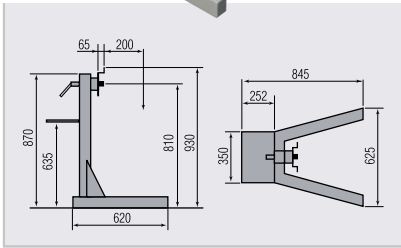

BANCO ROTATIVO / ROTATING ENGINE STAND / ROTATION STAND /  
SUPPORT ROTATIF / BANCO ROTATIVO PARA MOTORES

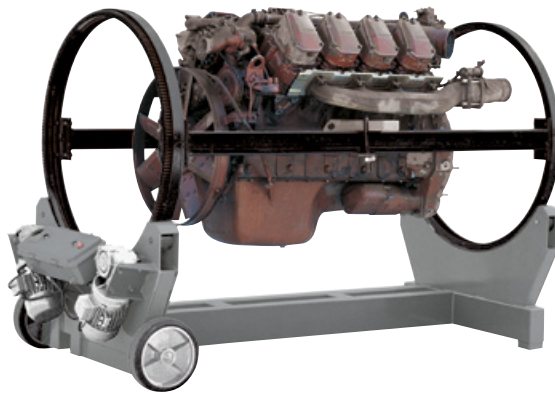
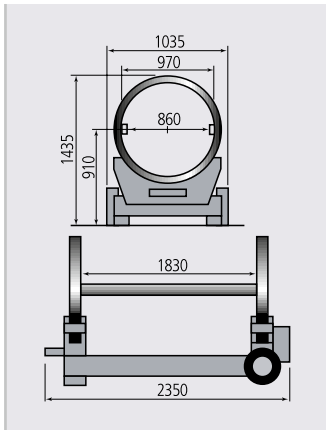

**R15**  
• 2.000 kg  
• 2x0,5 kW  
• 1 rpm



SABBIATRICE / SAND BLASTER / SANDSTRAHLKABINE /  
SABLEUSE / ARENADORA

DATI TECNICI	TECHNICAL DATA	TECHNISCHE DATEN	DONNEES TECHNIQUES	DATOS TÉCNICOS	R90N
Portello	Inlet door	Eingabe-Tür	Porte	Puerta	mm 645x295
Piano di lavoro	Working surface	Arbeitsfläche	Surface de travail	Plano de trabajo	mm 500x750
Pressione di esercizio	Working pressure	Betriebsdruck	Pression de service	Presión de trabajo	Bar 8
Consumo aria	Air consumption	Luftverbrauch	Consommation d'air	Consumo de aire	lt/1' 300
Aspiratore	Aspirator	Luftsauger	Aspirateur	Aspirador	Volt 220/380 3PH
Peso	Weight	Gewicht	Poids	Peso	kg 85

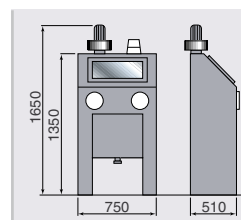

**R 90N**