





# Butler

# Torek 5

## BASELESS SERIES

**TOREK**  
**5.337**  
**5.349**

LIFTS

-  **SOLLEVATORI ELETTROMECCANICI A DUE COLONNE SENZA PEDANA**
-  **ELECTROMECHANICAL TWO POSTS BASELESS LIFTS**
-  **ELEKTROMECHANISCHE 2-SÄULEN-HEBEBÜHNEN MITTELSTEGFREI**
-  **ELEVATEURS ELECTROMECHANIQUES DEUX COLONNES SANS BASE**
-  **ELEVADORES ELECTROMECHANICOS DE DOS COLUMNAS SIN PEANA**

### TOREK5.337W / 3200 kg

Bracci corti a tre stadi per il sollevamento asimmetrico agevole anche di veicoli larghi - altezza minima tamponi di soli 95 mm.

*Three - stage short arms for asymmetric lifting of large vehicles - min. pad height 95 mm.*

Kurze Arme zweimal ausziehbar um leichter auch breite Fahrzeuge asymmetrisch hochzuheben - Unterschwenkhöhe nur 95 mm.

*Bras courts à 3 étages, pour faciliter le chargement asymétrique de véhicules larges des tampons de 95 mm.*

Brazos cortos de triple extensión, para el levantamiento de vehículos anchos también altura mínima de los tacos del suelo solamente 95 mm.



### TOREK5.337WK / 3200 kg

Bracci predisposti per l'alloggiamento rapido di prolunghhe.

*Arms suitable for quick drop-in extensions.*

Aufnahmen mit Schnellstecksystem erleichtern den Einsatz von Verlängerungen.

*Bras prédisposés pour le montage rapide de rallonges.*

Brazos predispuestos para el alojamiento rapido de extensiones.

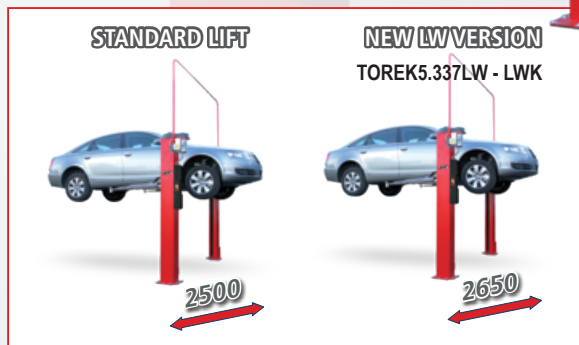

Lubrificazione permanente e automatica delle chiocciolate per garantire una lubrificazione efficace durante il movimento di salita e discesa

*Automatic and permanent nut lubrication system to guarantee efficient lubrication during lifting and descent*

Automatische Dauerschmierung der Muttern für eine wirksame Schmierung beim Hoch- und Runterfahren

*Lubrification permanente et automatique des écrous, efficace pendant la montée et la descente*

Lubrificación permanente y automática de las tuercas para garantizar una lubricación eficaz durante el movimiento de subida y bajada

Chiocciola portante in bronzo ad elevata resistenza all'usura (non plastica) a garanzia di sicurezza totale

*Main nut made of bronze (no plastic) with high resistance to wear, for greater safety*

Verschleißfeste Tragemutter aus Bronze (nicht Kunststoff) für eine totale Sicherheit

*Ecrou porteur en bronze à haute résistance à l'usure (pas de plastique) pour garantir une sécurité totale*

Tuerca principal en bronce de alta resistencia al desgaste (no es de plástico) para garantizar la seguridad total



Arresto bracci a inserimento automatico e sgancio automatico a terra - geometria conica con effetto autobloccante

*Automatic arm locking during lifting and automatic unlocking when the arm reaches the floor - self locking conical design*

Automatische Armarretierung, erleichtert durch eine konische Geometrie

*Blocage de bras automatique, dégagé au sol - géométrie conique autobloquante*

Bloqueo de brazos automatico y desenganche de brazos automáticamente del suelo - geometría conica con efecto auto-bloqueador



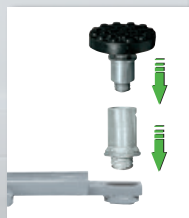

### TOREK5.349WELIK / 4000 kg

Modello equipaggiato con 4 bracci lunghi a tre stadi: ideali per il sollevamento di furgoni e furgonati a passo lungo, consente allo stesso tempo caricabilità ottimale anche per le autovetture.

Model equipped with four long three-stage arms: ideal to lift long wheel base vans and easy lifting of cars.

Modell mit vier zweifach ausziehbaren langen Armen: ideal zum Heben von Lieferwagen auch mit langem Radstand und garantiert auch eine optimale Aufnahme von PKWS.

Élévateur équipé de quatre bras longs à trois étages: idéal pour le levage de fourgons à châssis long, il garantit aussi le levage optimal des voitures.

Modelo equipado con 4 brazos largos de tres extensiones: ideal sea para el levantamiento de furgonetas normales y de chasis largo sea de turismos.

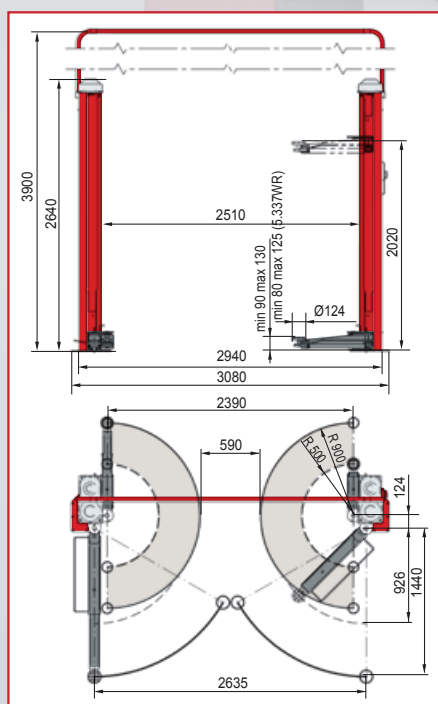

TOREK 5.337W / 5.337WK

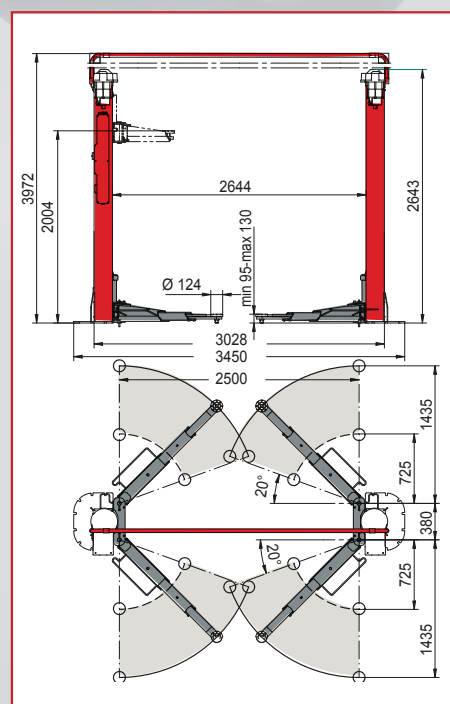

TOREK 5.349WELIK

### OPTIONS



**S224A4** (→ K models)  
140 mm extensions (4 x kit)

**S224A3** (→ K models)  
80 mm extensions (4 x kit)



**S5.337A2**  
Transporter frame adapter (2 x kit)

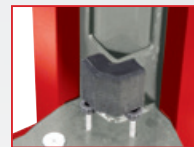

**S5.337A9 (2 x kit)**  
Set parasportelli  
Set of door protections  
Satz Türanschläge  
Kit protection portes  
Juego de protecciones para puertas