

MADE IN  
**ITALY**

**BO**  
1988-2018

**Butler**

**Torek**

**BASELESS SERIES**  
**HEAVY DUTY: 5500 kg**

**TOREK**  
**55ELIKT**  
**55ELIKTA**

LIFTS



-  **SOLLEVATORI ELETTROMECCANICI  
A DUE COLONNE SENZA PEDANA**
-  **ELECTROMECHANICAL  
TWO POSTS BASELESS LIFTS**
-  **ELEKTROMECHANISCHE  
2-SÄULEN-HEBEBÜHNEN MITTELSTEGFREI**
-  **ELEVATEURS ELECTROMECHANIQUES  
DEUX COLONNES SANS BASE**
-  **ELEVADORES ELECTROMECHANICOS  
DE DOS COLUMNAS SIN PEANA**





Bracci corti a maggiore estensione, raccomandati per il carico di veicoli fuoristrada. Bracci predisposti per l'alloggiamento rapido di prolunghe.

Short arms with longer reach, recommended to lift off-road vehicles. Arms suitable for quick drop-in extensions.

Kurze Arme länger ausziehbar, geeignet zum Hochheben von Geländewagen. Aufnahmen mit Schnellstecksystem erleichtern den Einsatz von Verlängerungen.

Bras courts avec longueur augmentée, indiqués pour le levage de véhicules tout-terrain. Bras prédisposés pour le montage rapide de rallonges.

Brazos cortos de mayor extensión, recomendados para el levantamiento de todo terrenos. Brazos predispuestos para el alojamiento rapido de extensiones.



### TOREK 55 ELIKT / 5500 kg

Modello equipaggiato con 4 bracci extra lunghi a tre stadi: ideali per il sollevamento di furgoni e furgonati a passo lungo incluso Mercedes Sprinter e VW Crafter.

Model equipped with four extra long three-stage arms: ideal to lift long wheel-base vans like Mercedes Sprinter and VW Crafter.

Modell mit vier zweifach ausziehbaren extra langen Armen ausgestattet: ideal zum Heben von Lieferwagen auch mit langem Radstand wie Mercedes Sprinter and VW Crafter.

Élévateur équipé de quatre bras extra longs à 3 étages: idéal pour le levage de fourgons à châssis long inclus les Mercedes Sprinter and VW Crafter.

Modelo equipado con 4 brazos extra largos de tres extensiones: ideal sea para el levantamiento de furgonetas normales y de chasis largo incluido Mercedes Sprinter and VW Crafter.



### TOREK 55 ELIKTA / 5500 kg

Versioni con due bracci lunghi a 3 stadi e due a 4 stadi, consentono caricabilità ottimale anche per le autovetture.

Models equipped with two long 3-stage arms and two long 4-stage arms, to allow easy lifting of large cars.

Ausführungen mit zwei zweifach und zwei dreifach ausziehbaren langer Armen, um eine optimale Aufnahme von PKWs auch zu garantieren.

Versions équipées de deux bras longs à 3 étages et deux à 4 étages pour garantir aussi le levage optimal de voitures.

Versiones con dos brazos largos de 3 extensiones y dos de 4 extensiones, por el levantamiento también de turismos.

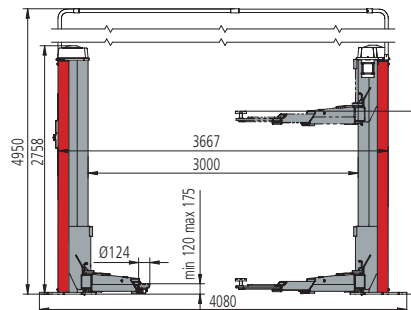

### TOREK 55 ELIKT

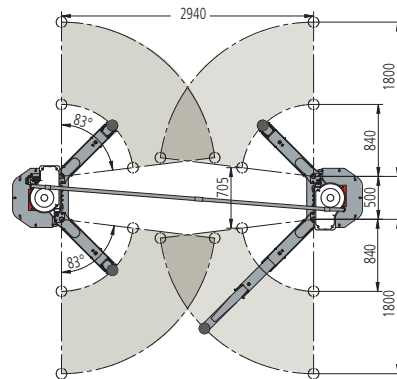

### TOREK 55 ELIKTA

