





MADE IN  
**ITALY**

**Butler**

# Navigator **EXTREME**

**DOUBLE CARRIAGE MOVEMENT**

-  **SMONTAGOMME**
-  **TYRE CHANGERS**
-  **MONTIERMASCHINEN**
-  **DEMONTE-PNEUS**
-  **DESMONTADORAS**



**UNIVERSAL TYRE CHANGER  
FOR EXTREME WHEEL DIMENSIONS**

**SMONTAGOMME UNIVERSALE  
PER DIMENSIONI RUOTA ESTREME**

**NAV  
73.17**

TYRE CHANGERS



Smontagomme elettroidraulico per pneumatici di autocarri, macchine agricole e movimento terra. Le dimensioni e le corse di lavoro consentono di operare con la massima efficienza su tutta la gamma di pneumatici.

*Electrohydraulic tyre changer for trucks, agricultural and earthmoving vehicles. The dimensions and work strokes are such as to ensure maximum efficiency for the entire range of tyres.*

Elektrohydraulische Reifenmontiermaschinen für Reifen von LKWs sowie Landwirtschafts- und Erdbewegungsmaschinen. Dank den Abmessungen und den Arbeitsabläufen wird auf dem ganzen Reifenbereich grösste Effizienz gewährleistet.

*Démonte-pneus électro-hydrauliques pour pneus de poids lourds, machines agricoles et engins de terrassement. Les dimensions et les courses de travail permettent d'opérer avec un maximum d'efficacité sur toute la gamme de pneus.*

Desmontadora electrohidráulica para neumáticos de camiones, máquinas agrícolas para trabajos de movimientos de tierra. Las dimensiones y las carreras motrices permiten de trabajar con máxima eficiencia en cualquier neumático.

**HIGH BEAD  
BREAKING FORCE**

Considerabile forza stallonatore per smontare e montare le gomme anche nei casi in cui rimangono montate al cerchio per lunghi periodi in miniere o cantieri.

*Thanks to its considerable bead breaking force mounting and demounting are effortless, even when working with tyres which have been left on the rim for a long period of time in construction sites or mines.*

Die bemerkenswerte Abdückerkraft erlaubt die Montage und Demontage von sehr schwierigen Reifen, die lange im Einsatz waren wie auf Baustellen, Hafen, und Zechen

*La force de détalonnage est considérable permet le montage et le démontage de pneumatiques restés sur la jante longtemps comme des chantiers, des ports ou des mines.*

La considerable fuerza de destalonamiento facilita el montaje y desmontaje de neumáticos que se han quedado pegados a la imanta durante mucho tiempo como zonas de obras, puertos o minas.

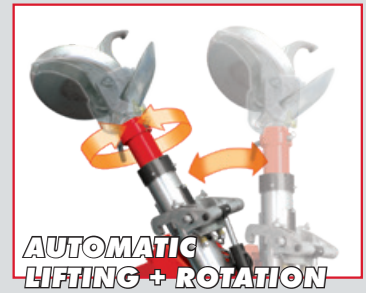

**FULLY AUTOMATIC  
DOUBLE CARRIAGE  
MOVEMENT**

**NAV 73.17**

**DOUBLE ROTATION SPEED**

Doppia velocità su movimento rotazione mandrino.  
*Double speed for chucking table rotation.*  
Spannvorrichtung mit doppelter Drehgeschwindigkeit.  
*Double vitesse pour rotation du mandrin.*  
Doble velocidad en movimiento rotación del plato.



**NAV 73.17+VARGNAV6315D**

**1-5-10 RPM  
ROTATION SPEED WITH INVERTER**

Velocità di rotazione mandrino regolabile con inverter a 12 / 6 / 1 rpm adatta anche per la scolpitura dei pneumatici.  
*Rotation speed adjustable with inverter at 12/6/1 rpm, also suitable for tyre treading.*  
Invertergesteuerte Drehgeschwindigkeit 12/6/1 rpm der Spannvorrichtung, geeignet auch zur Nacharbeitung der Reifenprofile.  
*Vitesse de rotation mandrin réglable avec inverter à 12 / 6 / 1 tour par minute, apte aussi pour le relief de la bande de roulement.*  
Velocidad de rotación del plato registrable con inverter a 12/6/1 rpm, apta para esculpir neumáticos también.

**CONTROL UNIT**



- 1 CLAMPS MOVEMENT 
- 2 BEAD BREAKING ARM MOVEMENT
- 3 DOUBLE SPEED
- 4 BEAD BREAKING ARM ROTATION 
- 5 CLAMPS ROTATION (4/8 RPM)
- 6 CLAMPS OPEN/CLOSE

**SPECIAL VERSIONS**

- VARGNAVBTB → NAV 73.17
- VARGNAVDBTH → NAV 73.17+VARGNAV6315D

Consolle di comando senza cavi  
*Wireless controle unit*  
Kabellose Steuersäule  
*Console de contrôle sans câbles*  
Consola de comando sin cables



## MINIMUM HEIGHT

330 mm (13")

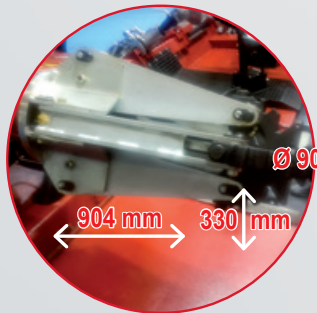

Ideale anche per molte ruote autocarro da 19" e 22,5".

*Ideal also for many 19" and 22,5" truck wheels.*

Ideal auch für 19" und 22,5" Räder.

*Idéal même pour roues PL de 19" et 22,5".*

También para ruedas de camión de 19" y 22,5".

## MINIMUM CLAMPING

Ø 90 mm (4")

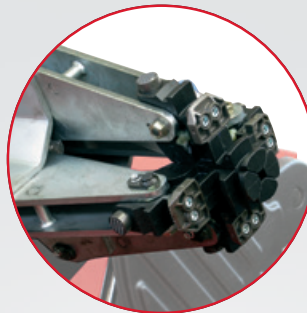

La griffa a gradini permette il bloccaggio interno a partire da 90 mm senza l'uso di accessori.

*The stepped claws allow 90 mm internal diameter clamping with no need of accessories.*

Die stufenförmige Spannklaue erlaubt das Aufspannen ab 90 mm ohne den Einsatz von Zubehör.

*La griffes à étages permet le blocage interne à partir de 90 mm sans l'utilisation d'accessoires.*

La garra "con escalones" permite el bloqueo interno a partir de 90 mm, sin el uso de accesorios especiales.

## ELECTRO-BRAKE

L'elettro-freno consente l'arresto immediato della rotazione per evitare danni al pneumatico.

*The electro-brake allows immediate stopping of the rotation to avoid any damage to the tyre.*

Eine elektrische Bremse arretiert sofort die Drehung, um Reifenbeschädigungen zu vermeiden.

*Le moteur est équipé d'un électrofrein qui permet l'arrêt immédiat de la rotation de la roue en évitant le risque d'endommagements du pneu.*

El electro-freno permite el bloqueo inmediato de la rotación para no dañar el neumático.

## MULTIPLE ADJUSTABLE GUIDES



## NAV 73.17

11" - 50"  
11" - 60" (→ G108A39)

2700 mm (106")

1750 mm (69")



## STAND-BY FUNCTION

Dopo 5 secondi di inutilizzo il motore si spegne.

*After 5 sec. the machine has not been used, the motor turns off.*

Bei nicht Benutzung geht nach 5 Sek. das Aggregat in Standby.

*Après 5 secondes sans utilisation le moteur s'éteint et le démonte-pneus se positionne en état d'attente.*

Después de 5 segundos de no utilizar el motor se apaga.

Il mandrino di grandi dimensioni consente di operare su ruote "speciali" senza rischio di interferenza con il braccio mandrino, garantendo inoltre il bloccaggio fino a 50" pollici senza l'utilizzo di estensioni.

*The big chucking dimension permits to work on extreme tyres without any interference with the chucking arm, granting also to reach 50" Inch without any need of extensions.*

Großdimensionierte Spannvorrichtung für einen Einsatz auch auf "Spezialräder" ohne Beeinträchtigung seitens des Spannfutterarm. Spannbereich bis 50" ohne Gebrauch von Verlängerungen

*Le mandrin de grand dimensionnes il permette de travailler aussi sur roues spécial sans risque d'interférences avec le bras mandrin Il assure également le verrouillage jusqu'à 50" sans l'utilisation d'extensions*

El plato de grandes dimensiones facilita el trabajo con ruedas "extremas y especiales" sin riesgos de interferir con el brazo mandril y, además, garantizando el bloqueo hasta 50 pulgadas utilito de extensiones.



## STANDARD

- 1 leva alza talloni
- 1 morsetto per cerchi
- 1 bead lifting lever
- 1 rim clamp
- 1 Montiereisen
- 1 Klemme
- 1 levier de soulèvement
- 1 étai pour jante
- 1 leva para talón
- 1 morzada para llanta



## OPTIONS

### Protezioni - Protections - Alufelgenschutz Protections - Protecciones



#### G108A1

Kit protezioni per cerchi in lega (n°4 pezzi).  
4 clamp protections for alloy rims.  
Satz Alufelgenschutz (4 Stk).  
Kit de protection (n°4) pour jantes en alliage.  
Protección garras (n°4) para llantas de aleación.

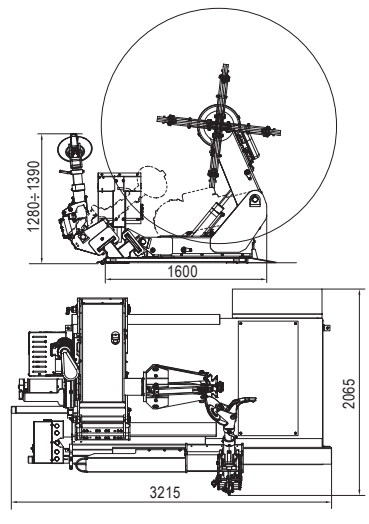

### Adattatori - Claws adapter - Adapter Adaptateurs - Adaptadores



#### G108A39

Serie prolunghe presa mandrino.  
Set of extensions to increase clamping capacity.  
Verlängerungen.  
Kit rallonges prise mandrin.  
Juego extensiones agarre plato.



#### G108A5

Adattatori ad aderenza maggiorata.  
Adapters with increased adherence.  
Adapter.  
Adaptateurs adhérence majeure.  
Adaptadores con adherencia suplementar.



#### G108A34

Premi tallone pneumatico  
Pneumatic bead pushing device  
Pneumatischer Wulstrücker  
Pousse-talon pneumatique  
Prensa talón neumático



#### VARGNAV63A.15

Comandi su braccio mobile.  
Version with controls off the ground.  
Steuerungen auf mobilem Arm.  
Version avec commandes sur bras mobile.  
Mandos en brazo móvil.



### Dispositivi vari - Various - Verschiedenes - Divers- Varios

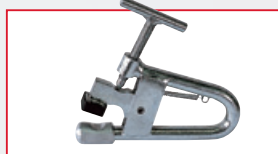

#### G90A6

Morsetto bloccatallone per cerchi in lega.  
Bead-locking clamp for alloy rims.  
Wulstklemme für Leichtmetallfelgen.  
Mors bloque-talon pour jantes en alliage.  
Mordaza de bloqueo talón para llantas de aleación.

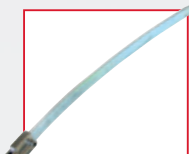

#### G108A3

Leva con testina.  
Lever with tool.  
Montiereisen.  
Levier.  
Palanca

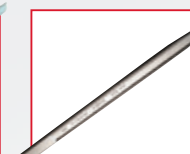

#### G108A13

Leva per cerchietti.  
Rings lever.  
Montierhebel.  
Levier pour bagues.  
Palanca para anillos.



#### G108A16

Pennello.  
Brush.  
Montagepinsel.  
Pinceau.  
Brocha profesional.



#### G800A37 (3,5 kg / 8 lb)

Pasta di montaggio.  
Mounting grease.  
Montagepaste.  
Pâte de montage.  
Jabón profesional

NOTE:  
8 x carton  
160 x pallet



#### VARGNAVGM

Cavo console con guaina in metallo  
Console cable with metal sheath  
Konsolenkabel mit Metallummantelung  
Câble de console avec gaine métallique  
Cable de consola con funda metálica

DATI TECNICI	TECHNICAL DATA	TECHNISCHE DATEN	DONNEES TECHNIQUES	DATOS TÉCNICOS		NAV73.17
Motore rotazione mandrino	Chucking unit rotation motor	Motor für Umdrehung der Spannvorrichtung	Moteur rotation mandrin	Motor rotación plato	kW	1,5 - 2,2
Motore centralina	Hydraulic drive unit motor	Hydraulikmotor	Moteur de la pompe	Motor unidad hidráulica	kW	1,8 - 2,5
Ø cerchi	Rim Ø	Felgen-Ø	Ø de la jante	Ø de llantas		11" - 50"
Ø cerchio con G108A39	Rim Ø with G108A39	Felgen-Ø mit G108A39	Ø de la jante avec G108A39	Ø de llantas con G108A39		11" - 60"
Ø est. ruota ammesso	Max. wheel Ø	Raddurchmesser	Ø de la roue	Ø máximo ext. rueda		2700mm - 106"
Larghezza max. ruota	Max. allowed wheel width	Max. Radbreite	Largeur maxi de la roue	Ancho max. rueda		1750mm - 69"
Foro bloccaggio min.	min. internal clamping	min. Aufspann Durchmesser	min blocage interne	min bloqueo interno	mm	90
Potenza stallonatore IN	Bead breaker power IN	Abdrückerkraft IN	Force du détalonneur IN	Force du détalonneur IN	N	42000
Potenza stallonatore OUT	Bead breaker power OUT	Abdrückerkraft OUT	Force du détalonneur OUT	Force du détalonneur OUT	N	42000
Peso max ruota	Max wheel weight	Maximales Radgewicht	Poids maxi de la roue	Poids maxi de la roue	kg	3000
Velocità di rotazione (giri/min)	Chuck rotation speed (rev/min)	Sperrvorrichtungs-Drehgeschwindigkeit (U./min.)	Vitesse de rotation du mandrin (tours/min.)	Velocidad de rotación mandril (rev./min.)	giri/min	1 - 5 - 10
Coppia max rotazione	Max. torque to chuck	Max. Sperrvorrichtungs-Drehmoment	Couple max. au mandrin	Par máx al mandril	Nm	6000
Peso macchina	Weight	Gewicht	Poids	Peso	kg	1680

# Butler

Engineering and Marketing S.p.A. a.s.u.  
Via dell'Ecologia 6 - 42047 Rolo (RE)  
Ph. +39-0522-647911 - Fax +39-0522-649760  
www.butler.it - info@butler.it

a DOVER company

Le caratteristiche tecniche e gli allestimenti presentati in questo prospetto possono subire variazioni. Le immagini riprodotte non sono vincolanti.  
Technical data and composition presented in this catalogue may vary. Pictures reproduced are only indicative.  
Die techn. Daten und die Ausrüstungen, die in diesem Prospekt enthalten sind, können Änderungen erfahren. Deshalb sind die Abbildungen unverbindlich.  
Les caractéristiques techniques et les compositions présentées dans ce prospectus peuvent subir des variations. Les images reproduites n'ont qu'une valeur indicative.  
Las características técnicas y las composiciones ilustradas en este folleto pueden sufrir variaciones. Las imágenes propuestas son solamente indicativas.